

# Galileo Series

HIGH PRESSURE HOMOGENIZERS AND PLUNGER PUMPS SINCE 1974



The new table top homogenizer

## Quark

The compact single plunger lab homogenizer for reliable scale up from test to production. Suitable also for abrasive and viscous product

Available Atex configuration

**Powered by Interpump Group**

Patent pending

### TECHNICAL DATA

Plunger number	1
Weight (Kg)	50
Water consumption (l/h)	10
Product inlet/outlet	welding flanges DIN 11851
Minimum volume	10 ml

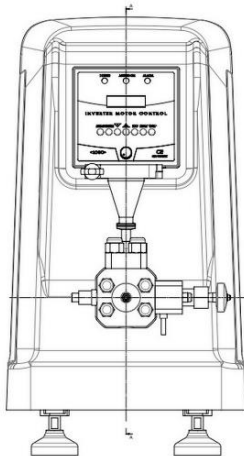

**Powered by a patented system with torque motor and recirculating ball screw providing a constant flow through the homogenizing valve and an optimum feeding capability overcoming drawbacks of single plunger piston pumps.**

Design according to MACHINE DIRECTIVES and the HARMONIZED EUROPEAN STANDARD in force.



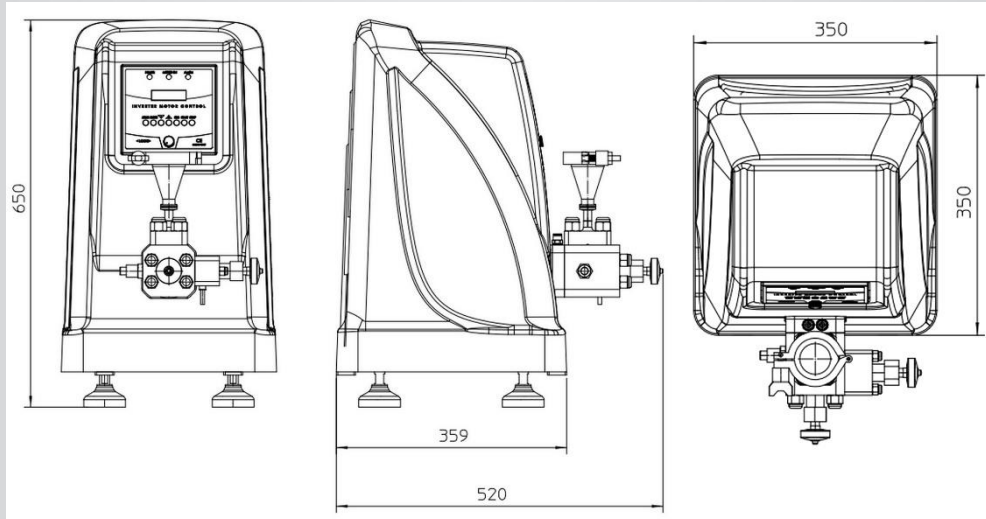

## FEATURES

Single plunger table top homogenizer up to 3 lt/h – 2.000 bar

Super duplex (SAF2507) compression head

Pumping group with tungsten carbide seat and Stellite balls

Double stage homogenizing group handwheel regulated with tungsten carbide homogenizing valves

Drive System with torque motor and recirculating ball screw

PLC control panel, prearranged for remote control

Standard 0.2 liters feeding hopper

## MAIN OPTIONS

Aseptic execution

3A, EHEDG or PHARMA design

- Low roughness and electropolishing of product wetted parts
- Certification manual for cGMP

Ceramic homogenizing valve, pistons and ball valves

Inlet and outlet connections

- DIN 11851, Tri Clamp, SMS
- High pressure outlet
- Option upon request

Sound proof design

Double stage and pump version

Skid version with feeding system and temperature control

Vibration and temperature monitoring and alarm

